

All dimensions are in millimeters (mm) unless otherwise noted

FOR USE IN

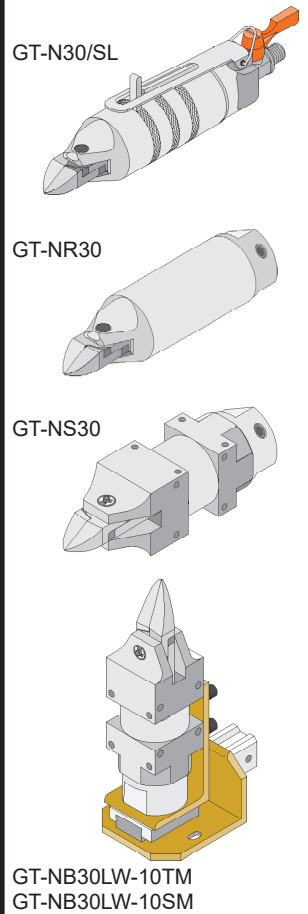

EFFECTIVE CUT:	18	APPLICATION:	WIRE / METAL
BLADE VARIATIONS		MATERIAL:	CARBIDE STEEL
ALLOY STEEL:	N30AG	EDP#	360172
CARBIDE:	N30BBB	AKA:	
HIGH SPEED STEEL:	CALL JDV	Rev.	Rev. Date: 02.03.2021
EQUIVALENT / ALTERNATIVE TO:			

MODEL NO.
N30BBB

VESSEL
PROFESSIONAL TOOLS

NIPPER BLADE

DRAWING #: BLNI 1255

VESSEL's Exclusive North American Distributor

Jdv JDV Products Inc.
22-01 Raphael Street, Fair Lawn, NJ 07410
Tel: 201-796-1720 Fax: 201-796-9399
www.vesseltools.com