

XP-F15

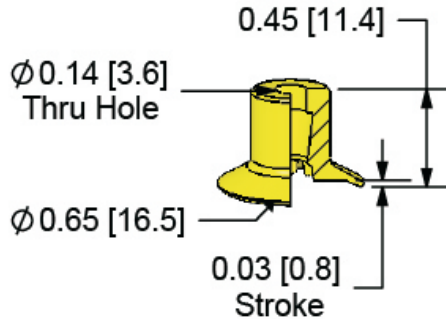

CUP DIAMETER	15 mm
CUP WEIGHT: oz. (g)	0.03 (0.85)
INTERNAL VOLUME: cu. in. (cc)	0.02 (0.33)
FORCE @ 6" Hg: lb. (N)	0.8 (3.6)
FORCE @ 18" Hg: lb. (N)	1.9 (8.5)
MINIMUM RADIUS: in. (mm)	0.51 (13)
SHEAR LOAD² : lb. (N)	0.9 (4)

MATERIAL - VITON



PART NUMBER

XP-F15V